

12 VG 100

BATTERY SPECIFICATIONS



GEL 12V100Ah

The Valen GEL – the solution for all your heavy cyclic applications! Valen Gel is a rechargeable, deep cycle, Valve Regulated Lead Acid (VRLA) battery. This high-quality Gel battery has met and exceeded all market expectations over the years, and today continues to prove its excellence by its ability to resist deep discharges and recovering after heavy draining.

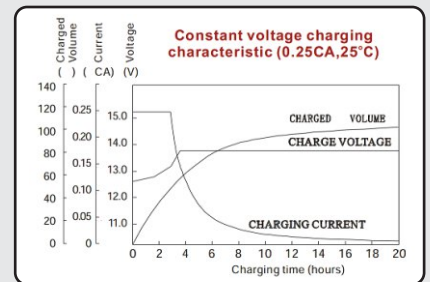
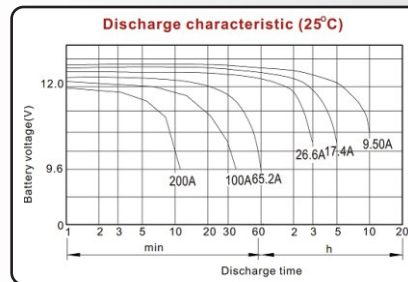
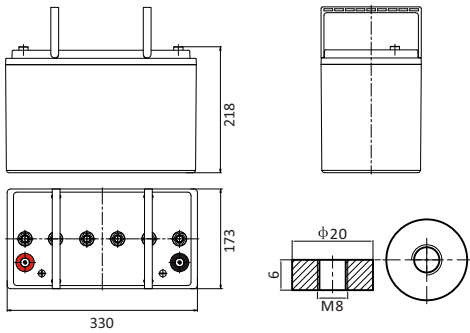

SPECIFICATIONS

Voltage	12 Volt nominal
Number of cells	6
Design life	10 years
Nominal Capacity 25°C	
20Hr rate (10.5V)	100Ah
10Hr rate (10.5V)	90Ah
5Hr rate (10.5V)	77.4Ah
Dimensions	330(L)x173(W)x218(H)
Weight	33.5Kg
Plates	Heavy duty
Terminal	Insert - M8
Container/cover	ABS
Charge voltage	Cycle: Maximum charge current - 30A Voltage 2.35 vpc at 25°C Standby Voltage: 2.25 vpc at 25°C
Internal Resistance	3.9mΩ 25°C - Fully charged Battery
Electrolyte	Thixotropic Gel - Sulphuric acid
Vent	Self-sealing – 2psi operation
Operating temperature:	-25°C to +55°C

(However it is recommended that the batteries be operated in the temperature range of 20 to 30°C to obtain full life and optimum performance.)

Discharge Constant Current (Amperes at 25°C)

End Point Volts/Cell	15min	30min	1h	3h	5h	10h	20h	100h
1.75V	151	89.9	54.1	23.7	15.5	9.00	5.00	1.11

Discharge Constant Power (Watts at 25°C)

End Point Volts/Cell	15min	30min	1h	3h	5h	10h	20h
1.75V	288	171	104	45.7	30.2	17.6	9.89

